

# SE1235

# SEAHORSE PROTECTIVE EQUIPMENT CASES

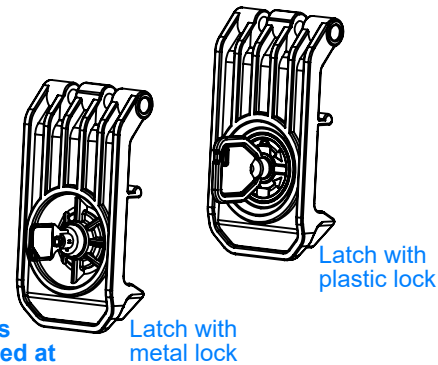
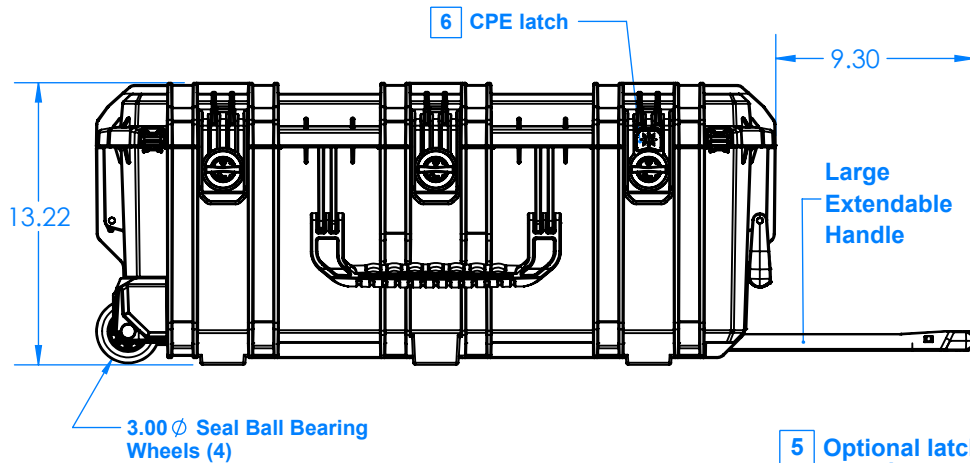
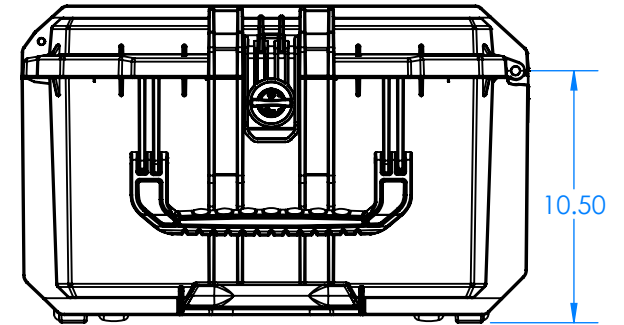
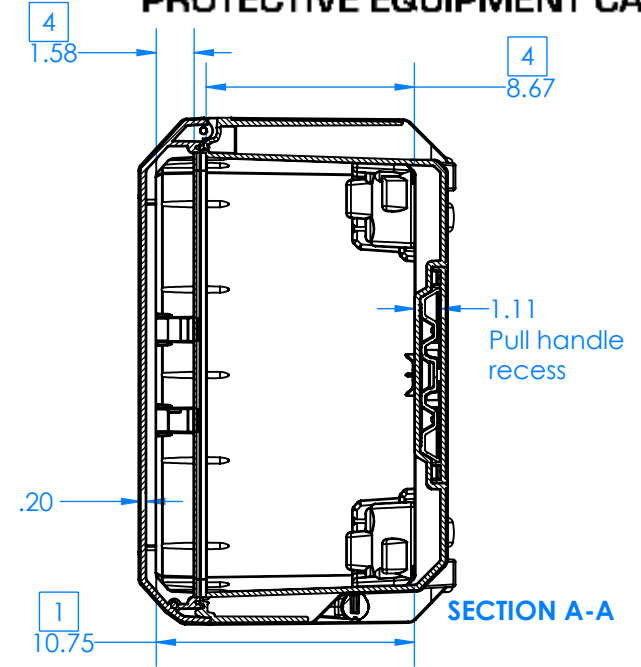
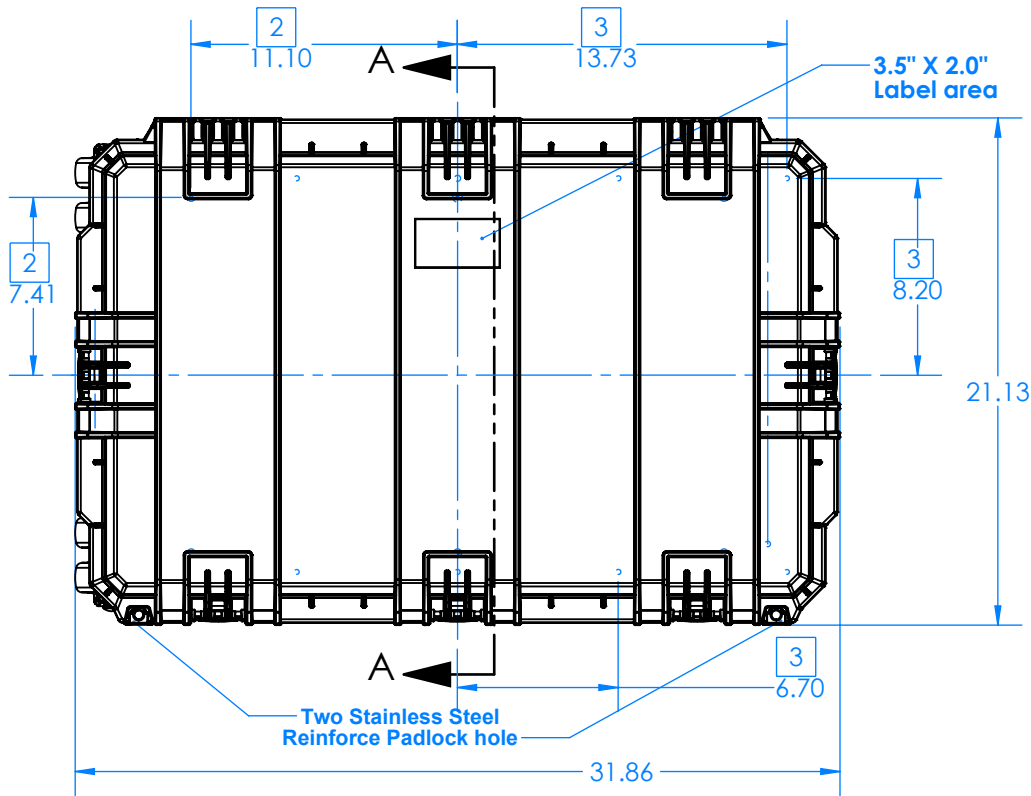

5 Optional latches must be specified at time of order

## NOTES:

- 1) Max. usable inside dimensions are: 28 13/16" X 17 1/2" X 10 5/8"
- 2) Bosses on Top use a #10 self tapping screw.
- 3) Bosses on bottom use a 1/4" self tapping screw.
- 4) Dimensions to bottom of panel flange.
- 5) Optional latches specify:  
SE1235ML with Metal Lock.  
SE1235PL with Plastic Lock.
- 6) CPE = Continues Pressure Equalization latch.